

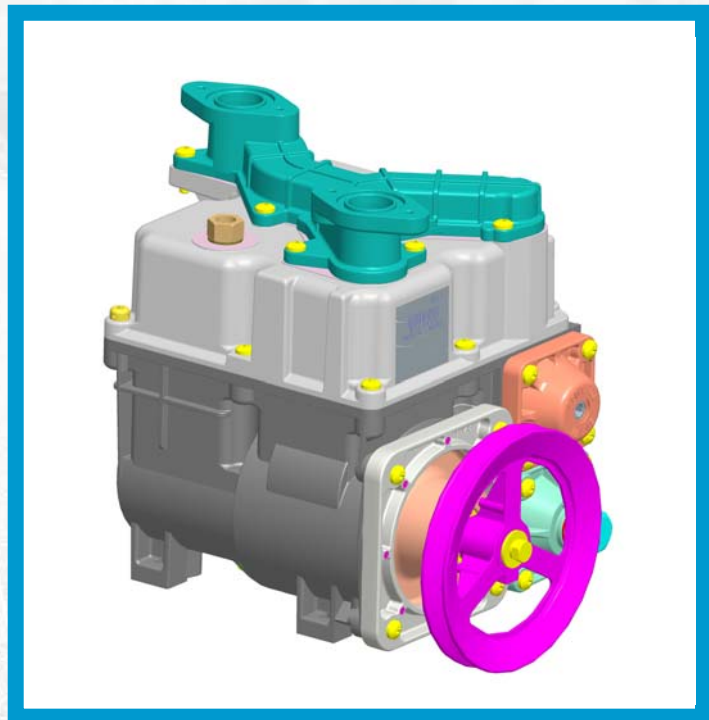

TQP-RS Pumping Unit Component Technical Manual



Document Ref 942006-001
Rev - 4
11/2011



Great care has been taken in the preparation of this manual however Tokheim shall not be liable for any misunderstanding, errors and/or loss or defect arising from the use of this manual.

Tokheim shall not be liable for damage to the product, nor for personal or third party injury, caused by incorrect use of the product or by attempts to maintain or to repair the product by parties other than those fully trained by Tokheim or by its accredited third party representatives.

Please contact your nearest service department, at the relevant address printed on the back cover of this manual, should any aspect of this manual be unclear.

© Copyright by Tokheim. All intellectual rights arising from, accruing to, and residing in this manual belong to Tokheim. No part of this document may be reproduced in any form without the express written permission of Tokheim.

Tokheim reserves the right to apply changes to this document and the equipment without further notice.

REVISION RECORD

Date	Revision	Page	Reason
05/07/2007	1	All	Original Issue
13/11/2009	2	4-4,4-11	Replaced vortex for EPZ
10/02/2011	3	-	New front & back cover
		1-1	Reference added for EPZ Manual
		1-5	New warning signs added
		1-6	Machinery directive changed to 2006/42/EC
		2-1	Section 2 Contents updated
		2-6	Above ground tank applications added
		Section 3	All reference to High Cover removed
		3-1	Section 3 Contents updated
		Section 4	Internal Filter - High Cover removed
		-	High Cover for Con. To MA26 Meter removed
		4-1	Section 4 Contents updated
		4-2 to 4-3	Pumping Unit drawing & parts list updated
		4-4 to 4-5	Pump By-pass etc drawing & parts list added
		4-6	Pump Cover drawing & parts list updated
		4-7	Internal Filter drawing & parts list updated
		4-8 to 4-9	External Filter Box drawing & parts list updated
		4-10	Float Valve drawing & parts list updated
		4-11	Air Separator parts list updated
		4-12	TQP-RS Assembly numbers added
24/11/2011	4	2-6 to 2-7	Remove all Tokheim 52 Valve references
12/03/2012	4.1(Sect.2)	2.6 to 2.7	Section 2.6.2 Above Ground Tank updated

This page is intentionally blank

CONTENTS

1 INTRODUCTION 1-2

1.1 How to Use this Manual 1-2

1.2 Product Scope 1-2

1.3 Authorised Technicians 1-2

1.4 Contact Information 1-2

1.5 Health & Safety 1-3

1.5.1 Safety Checklist 1-3

1.5.2 Duties of the Employees 1-3

1.5.3 Hazards 1-4

1.5.4 Warning Signs 1-4

1.5.5 Personal Protective Equipment (PPE) 1-5

1.6 Standards & Certificates 1-6

2 PRODUCT INFORMATION..... 2-2

2.1 Purpose 2-2

2.1.1 Filtration 2-2

2.1.2 Pumping 2-2

2.1.3 Air Elimination 2-2

2.1.4 Bypass 2-2

2.1.5 Outlet Control Valve 2-2

2.2 Technical Specifications 2-3

2.3 Cross Sectional Views 2-4

2.4 Description 2-5

2.5 Flow Diagram 2-6

2.6 Operating Description 2-6

2.6.1 Pumping, Filtration & By-Pass 2-6

2.6.2 Above Ground Tank Applications 2-6

2.6.3 Air Separation 2-7

2.6.4 Outlet/Control Valve & Safety Relief Valve 2-7

3 TQP-RS DIMENSIONED DRAWINGS 3-2

3.1 TQP-RS Dimensions 3-2

3.1.1 External Filter 3-2

3.1.2 No Filter 3-2

3.1.3 Internal Filter, rear flexible connection 3-3

3.1.4 Meter Collector Manifold 3-3

4 PARTS LISTS..... 4-2

4.1 TQP-RS Pumping Unit 4-2

4.2 Pump By-pass, Outlet Valve and Filter Cover 4-4

4.3 Pump Cover and Collector 4-6

4.4 Internal Filter 4-7

4.5 External Filter Box 4-8

4.6 Float Valve 4-10

4.7 Air Separator 4-11

4.8 TQP-RS Assembly Numbers 4-12

This page is intentionally blank

CONTENTS

1 INTRODUCTION..... 1-2

- 1.1 How to Use this Manual 1-2
- 1.2 Product Scope 1-2
- 1.3 Authorised Technicians 1-2
- 1.4 Contact Information 1-2
- 1.5 Health & Safety 1-3
 - 1.5.1 Safety Checklist 1-3
 - 1.5.2 Duties of the Employees 1-3
 - 1.5.3 Hazards 1-4
 - 1.5.4 Warning Signs 1-4
 - 1.5.5 Personal Protective Equipment (PPE) 1-5
- 1.6 Standards & Certificates 1-6

PLEASE REFER TO THE EPZ COMPONENT TECHNICAL MANUAL 903240-001 REGARDING ANY TECHNICAL INFORMATION AND SPARE PARTS USED BEFORE THE PUBLICATION DATE OF THIS MANUAL.

1 INTRODUCTION

1.1 How to Use this Manual

It is recommended that all relevant persons familiarise themselves with the contents of this manual prior to carrying out any operations or procedures.

This manual is divided into sections which are described as follows: -

Section 1 - Introduction

This section contains information on how to use the manual, the scope of equipment covered, recommendations on qualified technicians and contact information. It also includes relevant health and safety information required for the safe installation of the product.

Section 2 - Product Information

This section contains the system descriptions and operating principles of Tokheim's TQP-RS pumping unit.

Section 3 - TQP-RS Dimensions

This section provides the necessary dimensioned drawings of the TQP-RS in various configurations.

Section 4 - TQP-RS Parts List

This section details the assembly drawings and part identification lists for the TQP-RS.

1.2 Product Scope

This manual is designed to cover the TQP-RS pumping unit in Quantum 10 series dispensers.

1.3 Authorised Technicians

Only qualified technicians familiar with the contents of this manual should carry out the procedures contained herein.



WARNING : ANY ATTEMPTS TO CARRY OUT THE PROCEDURES OF THIS MANUAL, BY UNQUALIFIED OR UNAUTHORISED PERSONS, MAY RESULT IN SERIOUS INJURY OR LOSS OF LIFE.

NOTE : THIS MANUAL IS NOT INTENDED TO REPLACE THE SERVICES OF A FULLY QUALIFIED TECHNICIAN.

1.4 Contact Information

For information relating to the contents of this manual please contact: -

Technical Author
Tokheim UK Ltd.
Dundee, Scotland

For technical assistance please contact the appropriate service division listed on the back cover of this manual.

1.5 Health & Safety

1.5.1 SAFETY CHECKLIST

- It is obligatory that this checklist be fully complied with during all work at the petrol station, particularly construction or repair work.
- It is the duty of the contractor to ensure that all workers employed by him obey each and all of the relevant laws, directives and other regulations.

Areas where special caution is required

- The insides of tanks, tubes, dome shafts, filling shafts, change over shafts, vessels and dispensers.
- All areas in which fuel vapour that is heavier than air can accumulate, e.g. fuel separator, draining shafts, low located rooms, cellars, excavations, pipe trenches etc.
- The areas around the outlets of tank ventilation pipes, especially during the filling phase.
- All areas near dispensers, tanker lorries and other vehicles while they are being tanked up, and particularly when there is a lack of wind.
- A radius of 1.0 metres around petrol carrying pipes, as well as pipes that are not vapour free.
- Silt traps.

1.5.2 DUTIES OF THE EMPLOYEES

- To ensure optimal accident prevention in our company, in addition to general rules applying to worker's protection, it is necessary to take into account all the national protection of workers legislation and to actively support all measures which enhance safety standards.
- It is an employee's duty to follow all company directives regarding the prevention of accidents, unless such directives can be proved to be unfounded.
- Employees should not follow any instructions that go against safety standards.
- Employees are only permitted to use equipment for its original purpose, and this is defined by the company alone.
- If an employee detects equipment that is deficient in terms of safety, he shall eliminate this deficiency immediately. If such safety rectification is not part of his defined area of activities, or if his knowledge is insufficient to carry out such work he must immediately inform his superior about the detected safety deficiency.

This equally applies to:

- 1) **Work Materials** which have not been correctly packed or correctly marked in order to meet safety requirements.
- 2) **Work Methods** or work processes which have not been correctly coordinated or controlled in order to meet safety requirements.
- 3) **Where dangerous activities are carried out by several persons**, the need for a permanent faultless communication between them in order to avoid dangerous events shall require the appointing of one person in order to carry out overall supervision.

1.5.3 HAZARDS

Prior to starting work, the dispenser must be isolated (i.e. entirely disconnected from the mains supply) and the mains supply switch locked in the OFF position. The submerged pump (if applicable) and control signals from the dispenser must also be isolated. This is done to provide safety for the technician. As a further precaution, switch off the mains supply in the service station shop and place a clear notice on the switch to avoid it being turned on again inadvertently.



WARNING : THE CONNECTION AND DISCONNECTION OF ELECTRICAL CONNECTIONS MAY ONLY BE CARRIED OUT BY QUALIFIED PERSONNEL AUTHORISED FOR SUCH ACTIVITIES. WORK IN DANGEROUS AREAS MUST BE MADE SAFE BY OBSERVING ALL THE NATIONAL SAFETY REQUIREMENTS IN FORCE.

It is not permitted to put a fuel dispenser into operation before an authorised official has inspected it and released it. This depends upon the national regulations in force.



Dismantled packaging and cladding must be stored in such a way as to avoid damage to components or injuries to persons. Covers that can be opened, such as the calculator housing, should be handled with care. Ensure that the retaining catch is placed in the correct position to prevent the cover falling onto the head of the service engineer or other persons in the area.

At unattended service stations, every end-user should be able to read the User Instructions. They should be visible on a notice board or integrated into the DIT and should be sufficiently well lit so that they can be read at night.

At unattended service stations break away couplings must always be used to reduce the danger caused by a motorist driving off with the nozzle still in the tank.

1.5.4 WARNING SIGNS

The following warning signs are fitted as standard, on the dispenser, however they may vary according to individual country requirements or customer specifications.

SIGN	MEANING	POSITION
	Do not use mobile phones	Visible from both sides of dispenser
	No naked flames	Visible from both sides of dispenser



Do not spill fuel on the ground

Visible from both sides of dispenser



Smoking forbidden

Visible from both sides of dispenser



Stop vehicle engine

At Diesel high speed dispensers near the nozzle boots



Trucks only

Visible from both sides of dispenser

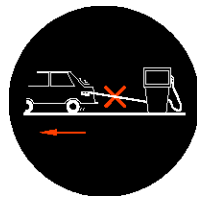

Do not drive away with nozzle in tank

Visible from both sides of dispenser

For more information see User Manual available at this station

Next to User Instructions near the nozzle boot

1.5.5 PERSONAL PROTECTIVE EQUIPMENT (PPE)

PROTECTIVE CLOTHING

The following clothing should be worn **at all times** during installation and maintenance procedures:-

- Protective helmet.
- Protective shoes (conductive).
- Protective gloves and/or protective hand cream.
- Anti static clothing.
- Eye protection.

SAFETY EQUIPMENT FOR WORKING IN HAZARDOUS AREAS

The following safety equipment is required for working in hazardous areas:-

- Only spark free tools are permitted for work on dispensers.
- Work on bearings is only permitted using the standard workshop tools authorised for this kind of work.
- The use of all electrical tools is strictly prohibited.
- Only the use of explosion protected work lights is permitted.
- The use of telecommunications equipment in hazardous areas is strictly prohibited.

SAFETY INSTRUCTIONS

The following safety instructions must be adhered to during installation and maintenance procedures:-

- Inhalation of petrol vapour must be avoided. Suitable precautions must be taken and where necessary respirators used.
- Avoid direct contact of fuel with the skin.
- Use suitable protective clothing, protective gloves and/or protective hand cream.
- Avoid fuel spills.
- No smoking, no naked flames are permitted.
- Long hair and ties can get caught in moving parts. Hair must be suitably covered.

1.6 Standards & Certificates

Tokheim TQP-RS pumping units are constructed in conformity with the requirements of all the applicable European Directives (Machinery 2006/42/EC; EMC 89/336/EEC; ATEX 94/9/EC).

The TQP-RS, MID cert TC7059 fulfills the requirements as mentioned in Annex 1 and Annex MI-005 of the Directive 2004/22/EC.

TQP-RS pumping units are incorporated into Tokheim fuel dispensers which conform to the essential requirements of the Machinery Directive 2006/42/EC.

The components used within the TQP-RS are selected in accordance with the European Standard EN BS 60079-0 (Electrical Apparatus for explosive gas atmospheres) and the supplementary Standards listed therein.

The production and end test is controlled through the Quality Assurance systems within the Tokheim Manufacturing Centres, and has received Quality Assurance Notification from a Notified Body.

No modification to the component may be performed without express permission from Tokheim and must always use original components or Tokheim retrofit kits. Failure to comply with the above will invalidate product conformance with the relevant European Directives and Tokheim will no longer accept product liability.

CONTENTS

- 2 PRODUCT INFORMATION 2-2**
 - 2.1 Purpose 2-2
 - 2.1.1 Filtration 2-2
 - 2.1.2 Pumping 2-2
 - 2.1.3 Air Elimination 2-2
 - 2.1.4 By-pass 2-2
 - 2.1.5 Outlet Control Valve 2-2
 - 2.2 Technical Specifications 2-3
 - 2.3 Cross Sectional Views 2-4
 - 2.4 Description 2-5
 - 2.5 Flow Diagram 2-6
 - 2.6 Operating Description 2-6
 - 2.6.1 Pumping, Filtration & By-Pass 2-6
 - 2.6.2 Above Ground Tank Applications 2-6
 - 2.6.3 Air Separation 2-7
 - 2.6.4 Outlet/Control Valve & Safety Relief Valve 2-7



2 PRODUCT INFORMATION

2.1 Purpose

The TQP-RS pumping unit is a standard product used in Tokheim dispensers.

It is a compact and lightweight unit manufactured with the following functions:

- Filtration (refer to section 2.1.1)
- Pumping (refer to section 2.1.2)
- Air elimination (refer to section 2.1.3)
- By-pass (refer to section 2.1.4)
- Outlet control valve (refer to section 2.1.5)

2.1.1 FILTRATION

Filtration is performed using a 90 μ filter supplied as standard with the external filterbox or 100 μ stainless steel filter supplied as standard with the internal filter. Alternative gauges and/or materials are available for specific requirements, for example 12 μ and 25 μ paper or nylon filters.

2.1.2 PUMPING

The same pumping unit can be used for both standard speed 40 l/min (2.4 m³/h) or high speed 80 l/min (5 m³/h) flow rates. With certain configurations, this can be achieved by changing the motor pulley in order to alter the pump rotation speed.

The unit uses a rotary vane pump with carbon blades and is capable of producing particularly high suction power even when the pump is dry.

2.1.3 AIR ELIMINATION

Air elimination is provided under a patented pseudo-static system, using a vortex effect, even within extreme standards.

2.1.4 BY-PASS

The bypass valve limits the maximum working pressure and therefore controls the flow rate of the pump.

2.1.5 OUTLET CONTROL VALVE

An outlet control valve is incorporated to allow fluid at a specific pressure to exit the pump and ensures all downstream hydraulic components are filled with liquid. It includes a relief valve to relieve excess pressure.

2.2 Technical Specifications

	40l/min (2.4m ³ /h)	80l/min (5m ³ /h)
Rotation speed	450 RPM	650 RPM
Maximum flow rate	50 l/min	83 l/min
Minimum flow rate	5 l/min	5 l/min
Noise level	68 dB	72 dB
Maximum pressure	2.5 bar	2.5 bar
Minimum motor power	370W	550W
Minimum dry suction	400mb	500mb
Minimum wet suction	700mb	700mb
Weight	14.5kg	14.5kg
Air elimination	In accordance with Regulation OIML R117/1995	
Filter	12μ, 25μ, 90μ (external); 100μ (internal)	
Bypass pressure adjustment	1.2 bar to 2.5 bar (approx. 0.1 bar per turn of the adjusting screw)	
Minimum inlet vacuum for correct operation	100mB	150mB

2.3 Cross Sectional Views

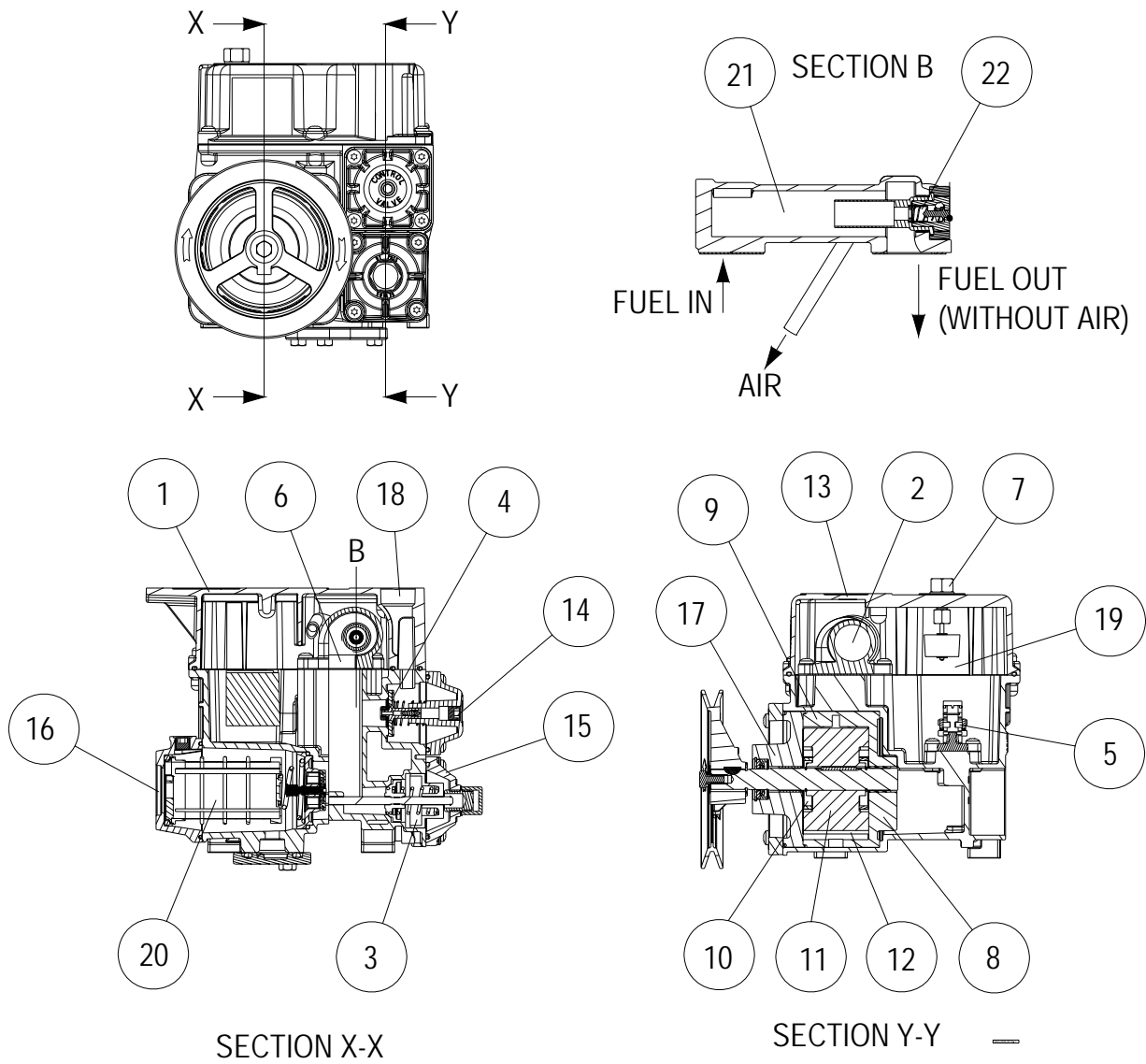

2.4 Description

The pumping unit comprises of the following main components:-

- Cast aluminium body (1).
- Top cover (13) with outlet manifold enabling connection to a remote meter via outlet chamber (18).
- Filter - with external filter box; or internal (20) either for rigid pipe connection at the bottom of the pump or flexible connection at the rear of the pump (16).
- Rotating pump assembly (9) with six radial carbon blades (12), comprising:-
 - Rotor (11) made of cast iron with a stainless steel shaft.
 - Stator (8) made of cast iron, tightly fitted inside the pump body.
 - Two free throw out rings (10) which maintain the contact between the blades and the stator.
 - Flange cover (17), also made of cast iron, that closes the pump chamber.
- Air separator assembly (2) with a patented pseudo-static device using a vortex effect comprising:-
 - Insert - air separator (6) which causes the fluid to rotate.
 - Cylinder in which foam and vapour are caught in the middle of the fluid which spins inside the vortex (21), then ejected through the vortex valve.
 - Vortex valve (22) to reduce internal leakage if the liquid is without air.
- 4.5 litre recovery chamber (19). The float valve assembly (5) provides for the recovery of liquid exiting the chamber, while air is evacuated through the air vent (7); equipped with float valve to prevent overflow risks.
- By-pass valve (3) with cover (15) for adjusting the maximum operating pressure, incorporating a by-pass pressure adjusting device.
- Control/outlet valve (4), enabling all downstream hydraulic components to be filled with liquid. This valve has a safety/check valve (14) for relieving excess pressure.

2.5 Flow Diagram

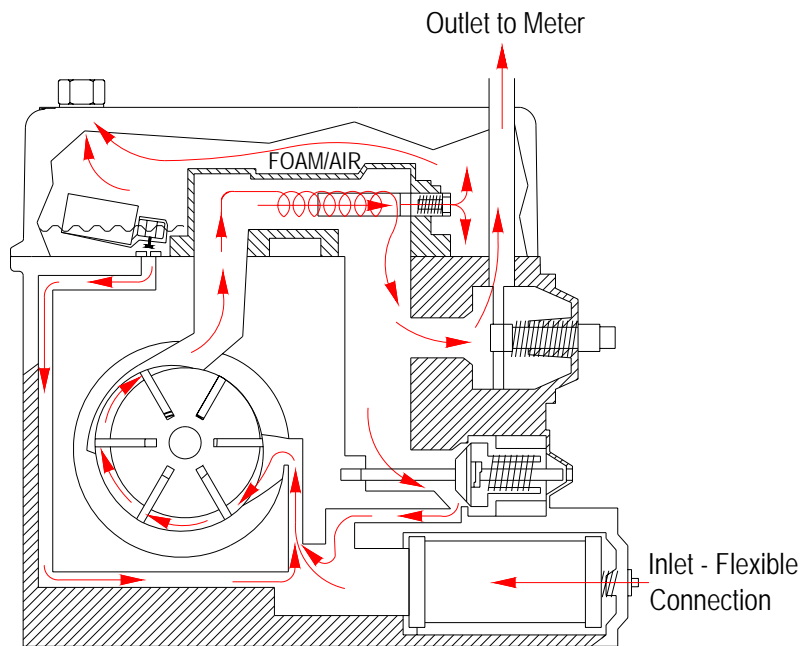

2.6 Operating Description

2.6.1 PUMPING, FILTRATION & BY-PASS

The product is drawn from its underground storage tank by the TQP-RS pump through the non-return valve into the filter - internal or external filter box.

The fluid is pressurised by the rotary vane pumping unit.

Product is accurately measured as it passes through the meter, then continues through the hose and nozzle into the vehicle tank. If the nozzle is not fully opened, liquid is fed back into the pump intake via the by-pass valve.

2.6.2 ABOVE GROUND TANK APPLICATIONS

The Tokheim suction pumps have been specifically designed to work in conjunction with underground tanks where the fuel level inside varies between 0.5 and 4 meters below the pump shaft. On suction pumps, minimal vacuum held on the suction line must be greater than 80mB to allow normal operation of pump and air elimination device.

Important!

Should dispensers be connected to 'above ground tanks' (partial or total), special care must be taken to avoid siphoning storage tanks via air vents or in case of leak/accident on connecting pipes, by using properly installed anti-siphon valves.

Please refer to state of the art equipment currently available and compliant with local/national rules/requirements. Eg: OPW anti-siphon valves.

Recommendation is to install this device at its highest point of piping, to allow for maximum protection.

Note : Tokheim cannot be held responsible for any equipment failure, accident or injury should these instructions not be followed.

2.6.3 AIR SEPARATION

The fuel enters the centrifugal air separator assembly. Any air present is forced, via the air tube, along with a small amount of liquid, into the recovery chamber. A vortex valve, located inside the air tube, regulates the flow to the recovery chamber. Air or vapour is sent through the vent and liquid is then collected in the recovery chamber. To avoid any air or vapour from entering the pump inlet, the float will not open until it has reached a predetermined level.

2.6.4 OUTLET/CONTROL VALVE & SAFETY RELIEF VALVE

Air-free fuel, exiting the air separator, causes the outlet/control valve to open and pumps the fuel to the meter. The outlet/control valve includes a built-in safety valve which relieves any excess pressure caused by expansion in hot weather.

This page is intentionally blank

CONTENTS

3 TQP-RS DIMENSIONED DRAWINGS 3-2

- 3.1 TQP-RS Dimensions 3-2
 - 3.1.1 External Filter 3-2
 - 3.1.2 No Filter 3-2
 - 3.1.3 Internal Filter, rear flexible connection 3-3
 - 3.1.4 Meter Collector Manifold 3-3



3 TQP-RS DIMENSIONED DRAWINGS

3.1 TQP-RS Dimensions

3.1.1 EXTERNAL FILTER

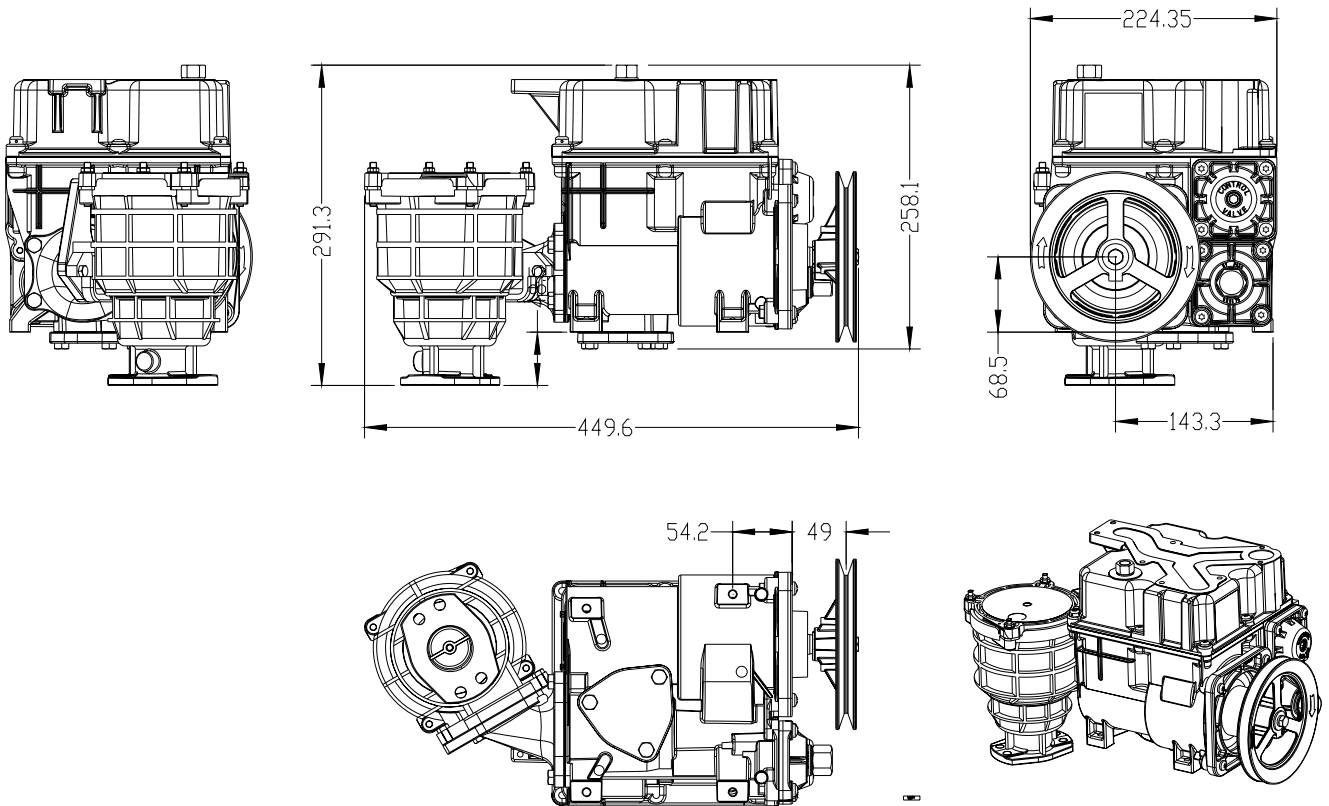

3.1.2 NO FILTER

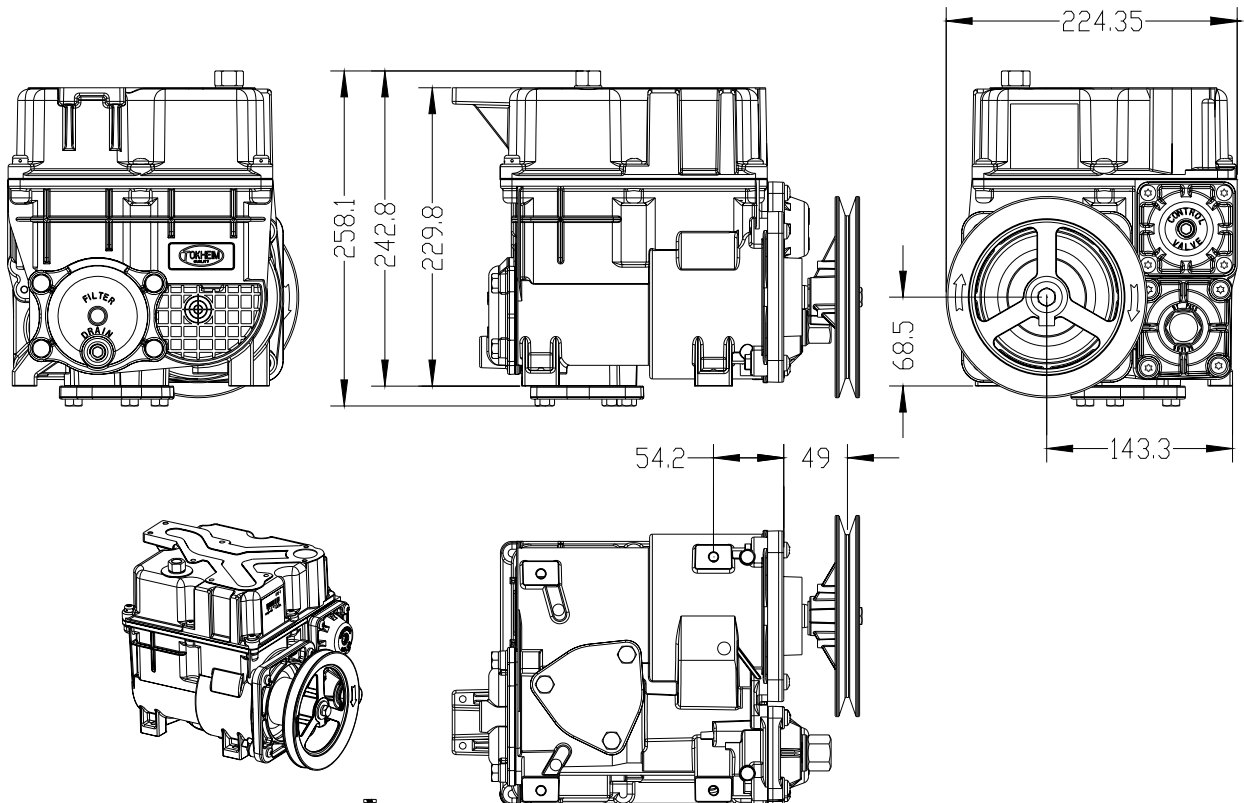

3.1.3 INTERNAL FILTER, REAR FLEXIBLE CONNECTION

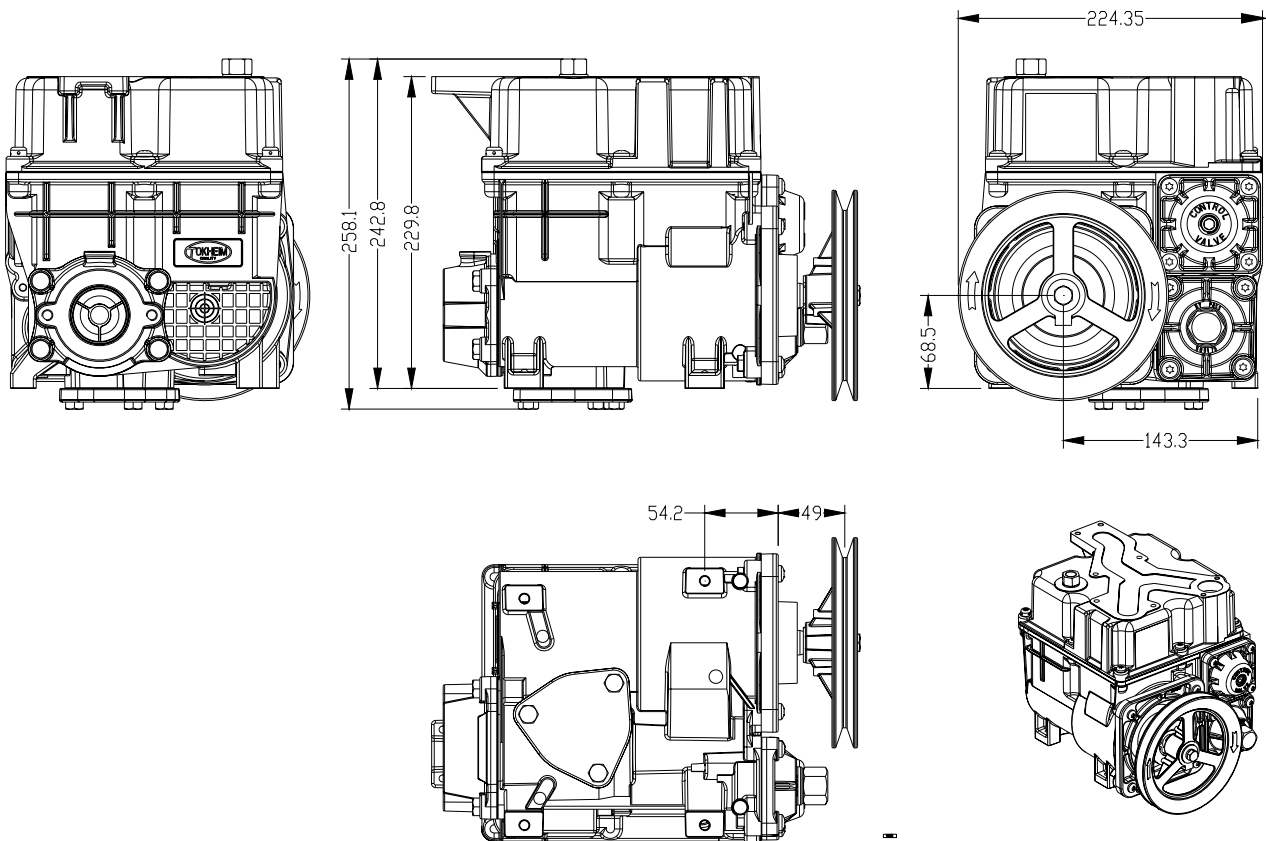

3.1.4 METER COLLECTOR MANIFOLD

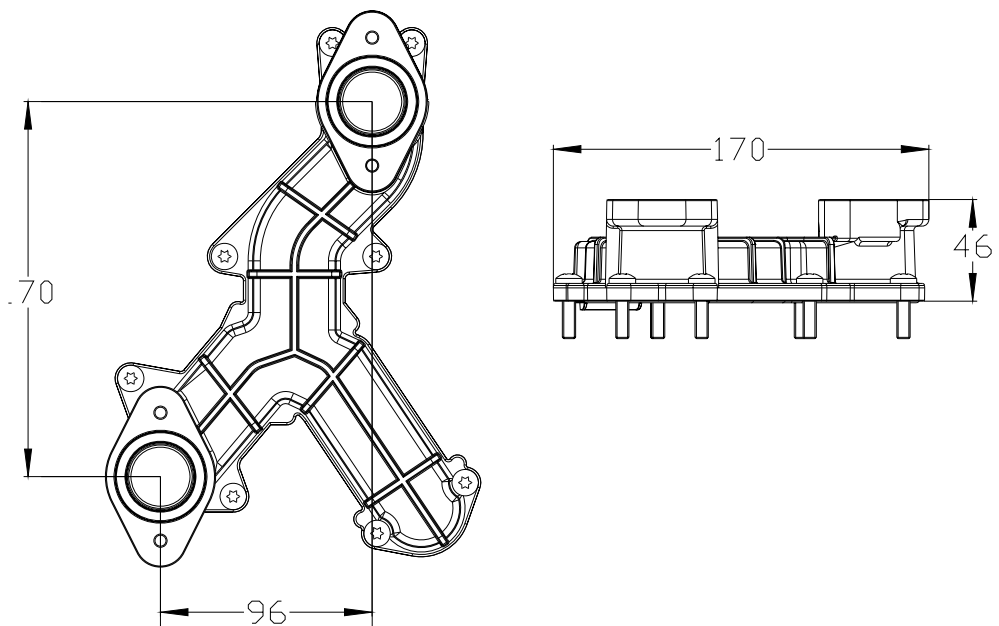

This page is intentionally blank

CONTENTS

4 PARTS LISTS 4-2

- 4.1 TQP-RS Pumping Unit 4-2
- 4.2 Pump By-pass, Outlet Valve and Filter Cover 4-4
- 4.3 Pump Cover and Collector 4-6
- 4.4 Internal Filter 4-7
- 4.5 External Filter Box 4-8
- 4.6 Float Valve 4-10
- 4.7 Air Separator 4-11
- 4.8 TQP-RS Assembly Numbers 4-12



4 PARTS LISTS

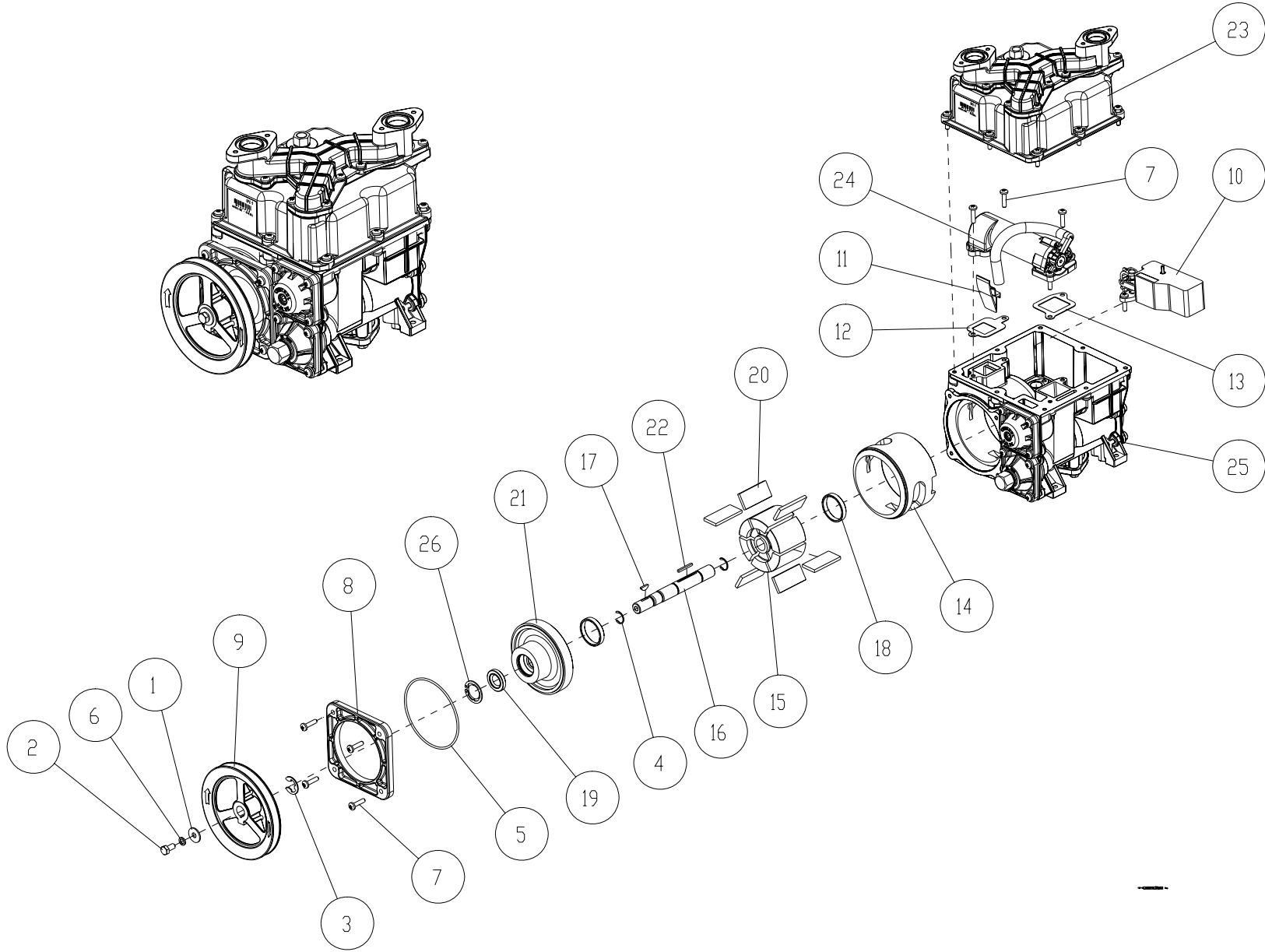

4.1 TQP-RS Pumping Unit

Item No	Description	Désignation Français	Part No	Comments
1	Washer PI d2=3xd1 M8	Rondelle PI d2=3xd1 M8	900008-006	
2	Screw HH M8x16	Vis H M8x16	900015-011	
3	Washer Retain Shaft (E) 15	Anneau Truarc (E) 15	900047-002	
4	Washer Retain Shaft 19	Anneau Truarc Croissant 19	900047-004	
5	O-Ring 112.00 x 3.00	Joint Torique 112.00 x 3.00	900050-012	
6	Washer Spring Lock M 8	Rondelle Elast. W 8	900051-005	
7	Screw Torx Thr Form BH M6	Vis Torx Auto FTCBL Trilob	900053-004	
8	Clamping Ring	Bride de Pompe	901213	
9	Pulley 1 Groove Pulley 2 Groove	Poulie 1 Gorge Poulie 2 Gorge	901214 903713	Handcrank Option
10	Float Assembly	Flotteur Assemble	-	Refer to Float Valve Assembly
11	Insert- Air Separator	Insert Du Separateur	901800	
12	Gasket Inlet	Joint Admis Separateur	901801	
13	Gasket- Outlet	Joint Refoulement Separateur	901802	
14	Stator Machined with Bearing	Stator Usiné et Bagué	901808	
15	Rotor Machined	Rotor Usin	901814	
16	Rotor Shaft	Axe du Rotor (woodruff)	901815	
17	Woodruff Key	Clavette Woodruff	901816	
18	Throw Out Ring	Bague du Guidage Palettes	901818	
19	Shaft Seal Shaft Seal 18x35x7	Bague Etancheite Bague Etancheite Arbre 18x35x7	901836 905102-001	Low Temperature
20	Blade	Palette du Rotor	903534	
21	Rotor Cover with Bearing	Flasque Equipé du Palier	904848	Standard & Std Low Temp.
22	Cotter Pin Form B 3x3x30	Clavette Parall Forme B 3x3x30	907020-001	
23	Pump Cover Equiped	Couvercle de Pompe Equipé	-	Refer to Pump Cover and Collector Asm
24	Assembly Separator Sst	Separateur Assemble Inox	-	Refer to Air Separator Assembly
25	Pump Body Machined w/o Valve	Corps Pompe Ssiné sans Valve	-	Refer to By-pass, Outlet & Filter Cover
26	Elastic Ring Stud Ø35	Anneau Elast a Ergot Int Ø35	948020-001	

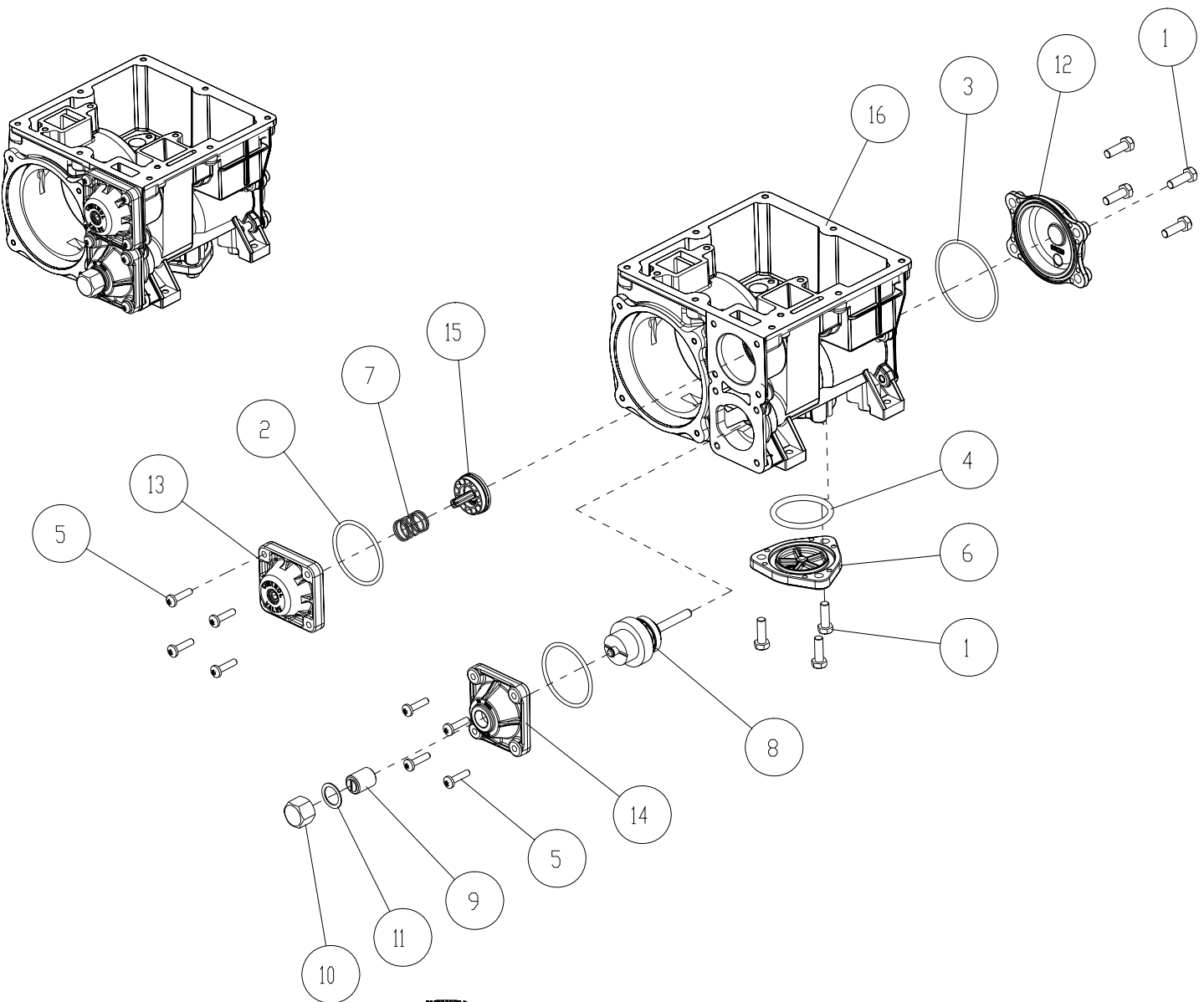

4.2 Pump By-pass, Outlet Valve and Filter Cover

Item No	Description	Désignation Français	Part No	Comments
1	Screw HH M8x25	Vis H M8x25	900015-012	
2	O-Ring 59.92x3.53	Joint Torique 59.92x3.53	900050-006	
3	O-Ring 78.00x3.00	Joint Torique 78.00x3.00	900050-008	
4	O-ring 50.17x5.33	Joint Torique 50.17x5.33	900050-031	
5	Screw Torx Thr Form BH M6	Vis Torx Auto FTCBL Trilob	900053-004	
6	Inlet Plug	Bouchon D'Aspiration	901238	
7	Outlet Valve Spring	Ressort Valve de Sortie	901703	
8	By-pass Assembly	By-pass Assemblé	901780	
9	Screw Adjustable By-Pass	Vis De Reglage Du By Pass	901786	
10	Cap- Adjustable- Bypass	Couvercle Reglage Bypass	901787	
11	Seal By-Pass	Joint Du Reglage By-Pass	901788	
12	Filter Cover with Screw	Couvercle Filtre avec Vis	906325	No Internal/External Filter
13	Checkvalve Cover with Pip Plug	Couvercle Clapet A-R avec Obtura	909178	
14	By-pass Cover	Couvercle de By-pass	909179	
15	Outlet Valve Equiped	Clapet de Sortie Equipe	944356	
16	Pump Body Machined w/o Valve	Corps Pompe Usiné sans Valve	947453	

4.3 Pump Cover and Collector

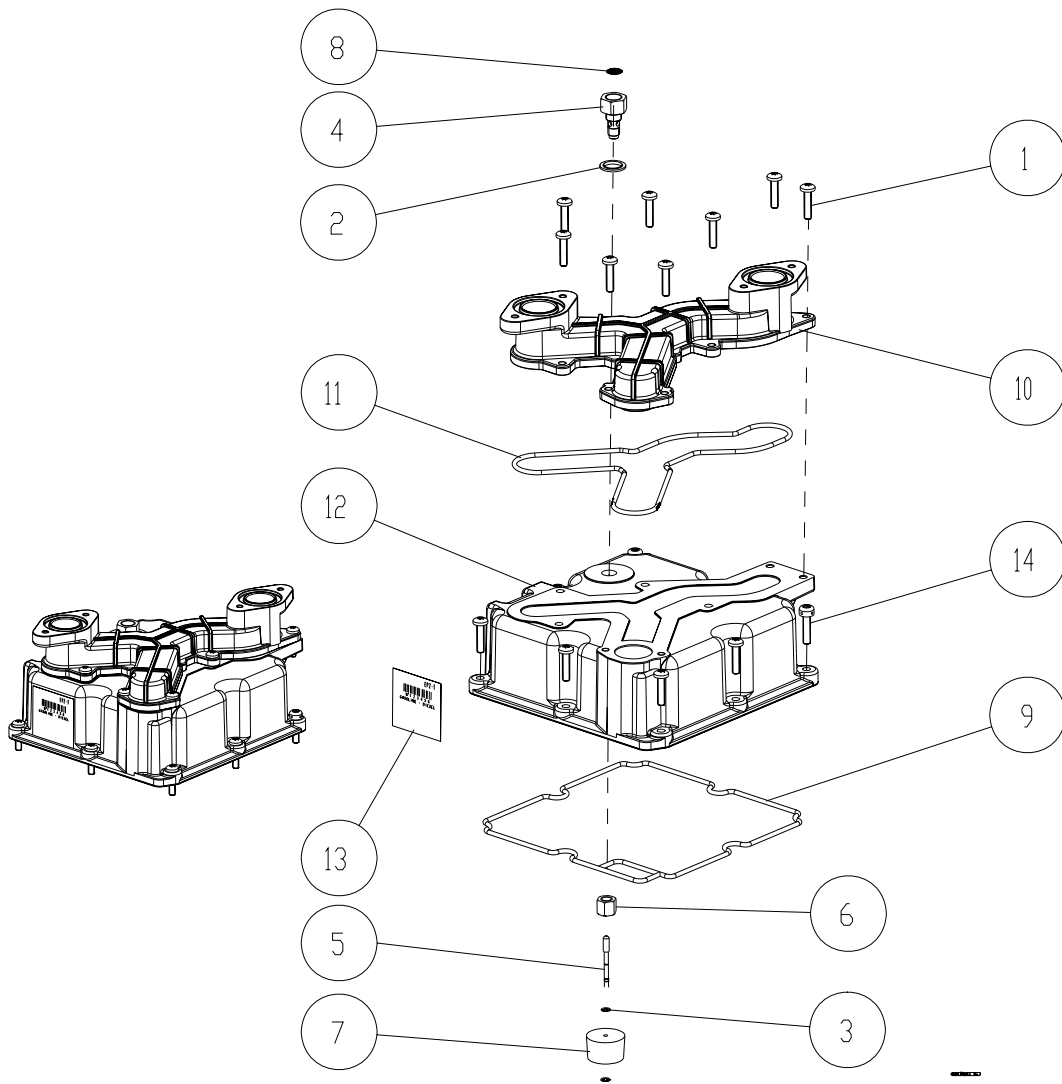

Item No	Description	Désignation Français	Part No	Comments
1	Screw Torx Thr Form BH	Vis Torx Auto FTCBL Tri	900053-004	
2	Dowty Seal Self Centre	Bague BS D14	900450-003	
3	Washer Spring Retain S	Anneau D'Arret Pour Axe	901313-001	
4	Valve Housing	Corps de Valve	901663	
5	Needle Valve	Valve de Aiguille	901664	
6	Gland Nut	Ecrou de Joint	901665	
7	Cork Float	Flotteur de Lity	901666	
8	Gauze - Flame Arrestor	Grillage Pare Flamme	902358	
9	Pump Cover Seal Stack	Joint Couvercle EPZ Sta	908524	
10	Collector SM80	Collecteur SM80	908526	
11	O-ring collector stack EP	Joint collecteur EPZ stad	908527	
12	Pump Cover	Couvercle de Pompe	909023	
13	Serial Label	Etiquette no. de Serie	901689-183	
14	Screw Torx Drill 2 Hole M	Vis Torx Percée 2 Trous	910027-001	

4.4 Internal Filter

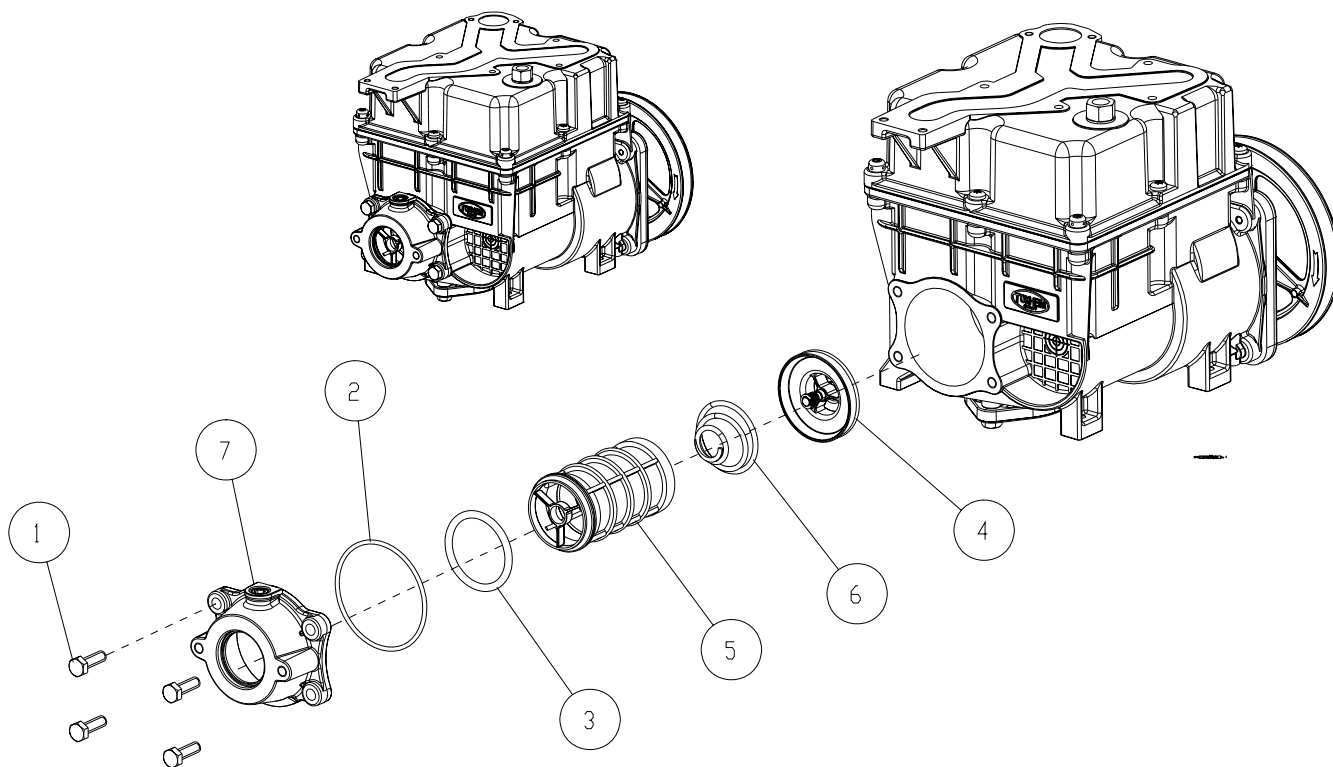

Item No	Description	Désignation Français	Part No	Comments
1	Screw HH M8x25	Vis H M8x25	900015-012	
2	O-Ring 78,00x3,00	Joint Torique 78,00x3,00	900050-008	
3	O-ring 50,17x5,33	Joint Torique 50,17x5,33	900050-031	
4	Check Valve Assembly	Clapet A/R de Filtre	904170	
5	Filter 100 microns Sst Internal Filter In-Out 25µ	Filtre 100 microns Inox Filtre Interne Int-Ext 25µ	906500 943036-001	Standard E85, Ethanol
6	Spring Filter Hose Inlet	Ressort Filtre Entree Flexible	906545	
7	Flange Internal Filter Assy	Bride Filtre Interne Asm	907032	

4.5 External Filter Box

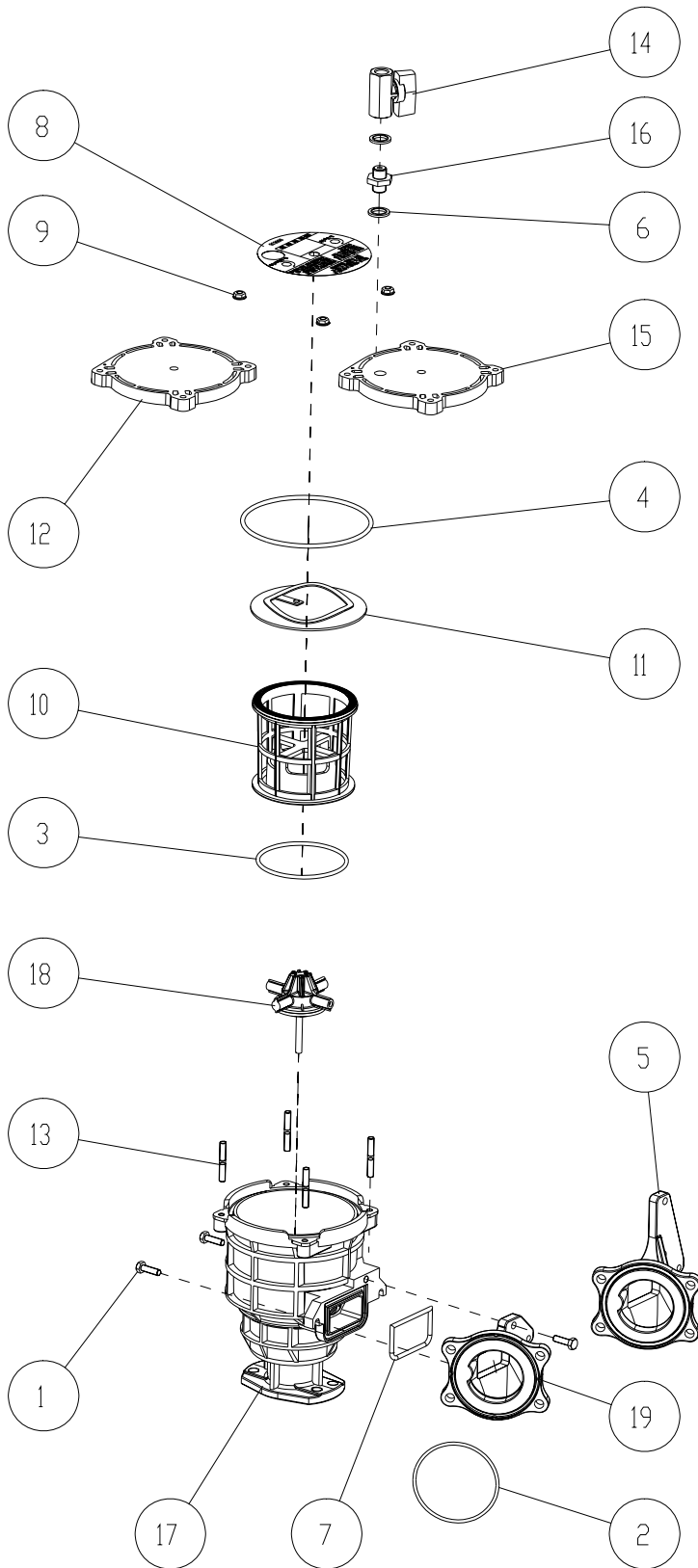

Filter Monitor Option

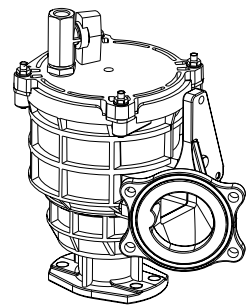

Standard

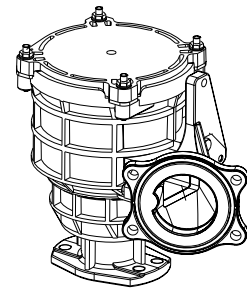

4.5 External Filter Box Parts List

Item	Description	Désignation Français	Part No	Comments
1	Screw HH M6x20	Vis H M6x20	900015-010	
2	O-Ring 78.00x3.00	Joint Torique 78.00x3.00	900050-008	
3	O-Ring 82.14x3.53	Joint Torique 82.14x3.53	900050-025	
4	O-Ring 120.00x4.00	Joint Torique 120.00x4.00	900050-027	Standard
	O-Ring 120.00x4.00	Joint Torique 120.00x4.00	900050-096	Low Temperature
	O-Ring 120.00x4.00 E85	Joint Torique 120x4.00 E85	900050-086	LT & Ethanol
5	Adaptor EPZ Filterbox	Adapt. EPZ Boite de Filtre	900358	Old Style Adaptor
6	Dowty Seal self centre 1/4"	Dowty joint torique 1/4" BSP	900450-001	Filter monitor
7	O-ring Filterbox	Joint Boite de Filtre	900635	
8	Sticker Filterbox Cover	Auto.couvercle Boite d'Filtre	900636	Standard
	Sticker Filterbox Cover LT	Auto.couvercle Boite d'Filtre	900636-002	Low Temperature
9	Nut Hex Serpress M6	Ecrou Serpress M6	901295-001	
10	Filter 90 Microns	Filtre 90 Microns	901612	Standard
	Filter 25 Microns	Filtre 25 Microns	901613	Option
	Filter 12 Microns	Filtre 12 Microns	901614	Option
11	Spring Plate	Plaque Supp. Equipee	901693	
	Spring Plate E85	Plaque Supp. Equipee E85	940206	Ethanol Compliant
12	Filter Box Cover	Couvercle Boite de Filtre	901694	
13	Stud M6x40 (18-4-18)	Goujon M6x40 (18-4-18)	901695	
14	Valve - Ball (Mini)	Vanne Spherique (Mini)	903472-001	Filter Monitor option
15	Cover - Adapted Filter Lid	Couvercle - Adapte Filtre	903473	Filter Monitor option
16	Assy - Check Valve	Asm - Clapet Anti-retour	903478	Filter Monitor option
17	Filterbox	Boite de Filtre	909769	
	Filterbox E85	Boite de Filtre E85	941256	Ethanol Compliant
18	Footvalve Filterbox	Clapet Filterbox	943260	
19	Adaptor Filterbox Light	Adaptateur Boite Filtre Light	943292	New Style Adaptor

4.6 Float Valve

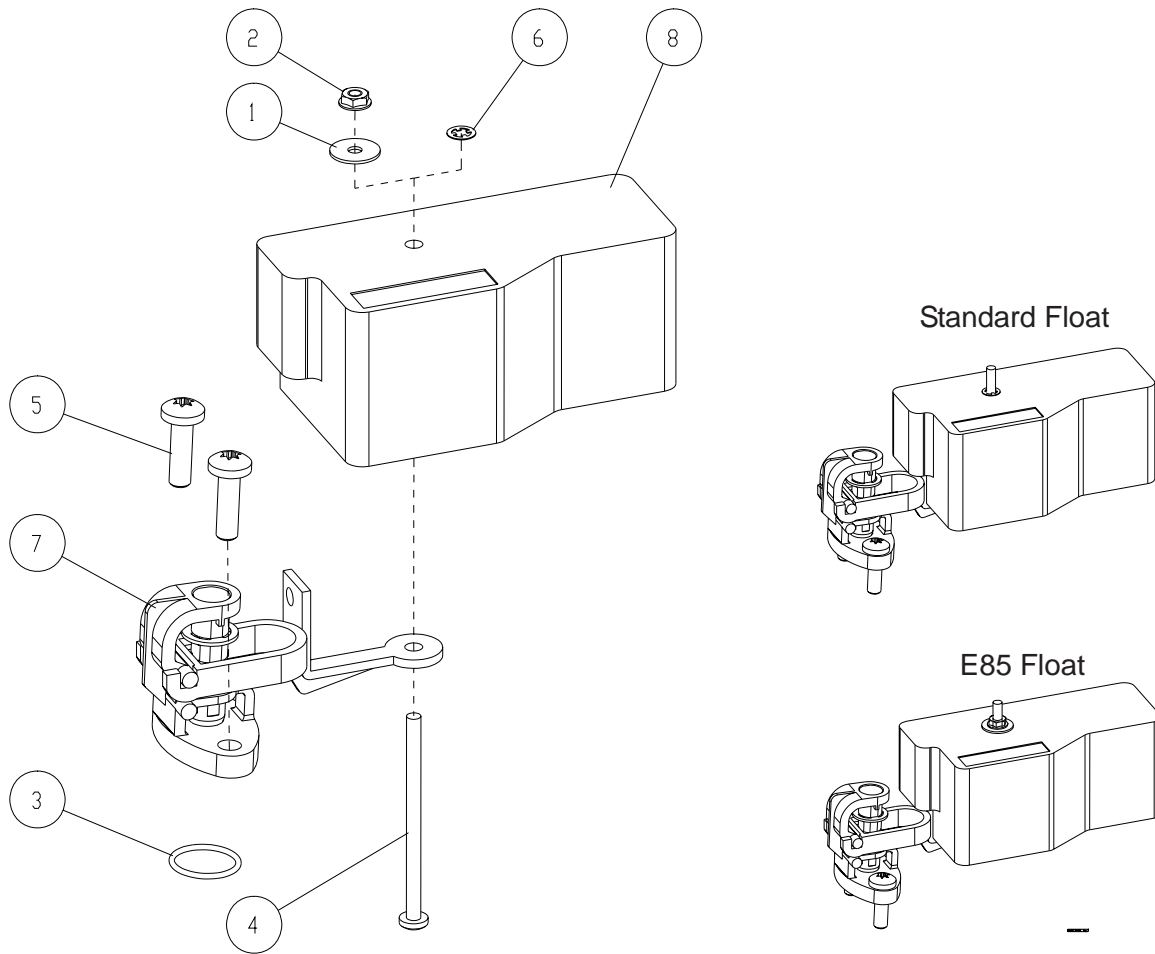

Item No	Description	Désignation Français	Part No	Comments
1	Washer PI L4	Rondelle PI L4	900008-018	E85 Ethanol only
2	Nut Hex Self Lock M4	Ecrou Bride Autobloquant M4	900013-001	E85 Ethanol only
3	O-Ring 17.00x1.50	Joint Torique 17.00x1.50	900050-004	
4	Screw CRRCH M4x60	Vis CBLZ M4x60	900052-001	
	Screw CRRCH M4x60	Vis CBLZ M4x60	900052-004	E85 Ethanol only
5	Screw Torx M6x25	Vis Torx M6x25	900053-004	
6	Washer Spring Ret. Shaft D3	Anneau D'Arret Pour Axe D3	901313-001	
7	Float Valve Assembly	Clapet Flotteur Assemble	901794	
8	Float	Flotteur	947274	

4.7 Air Separator

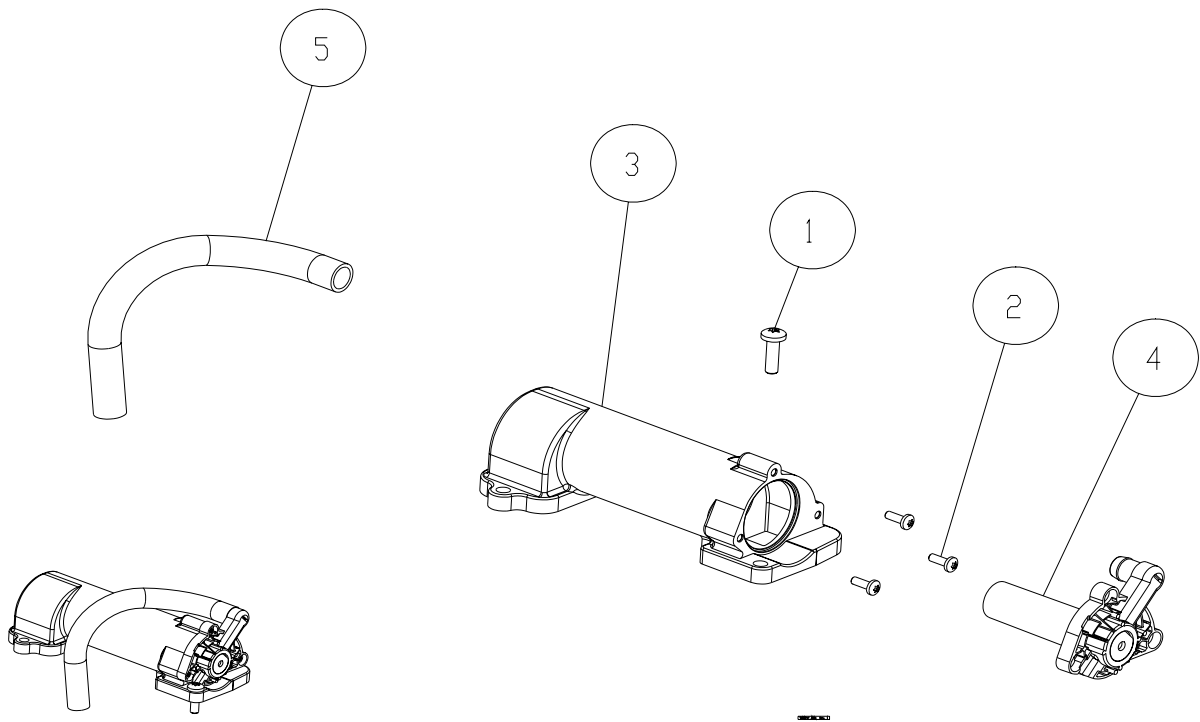

Item No	Description	Désignation Français	Part No	Comments
1	Screw Torx Th Frm BH M6x25	Vis Torx Auto TCBL Tril M6x25	900053-004	
2	Screw Torx Th Frm BH M4x12	Vis Torx Auto TCBL Tril M4x12	900053-005	
3	Air Separator Body	Corps Separateur	944092	
4	Vortex Assy Sst	Vortex Asm Inox	944096	
5	Vort. Ringed Flex Tube 205mm	Gaine Annelé du Vort. 205mm	947313-001	

4.8 TQP-RS Assembly Numbers

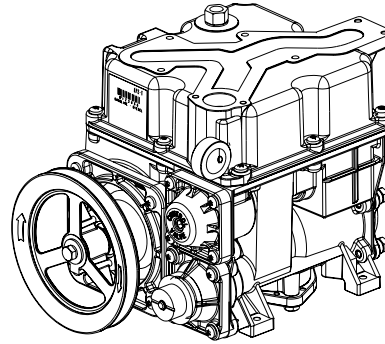

Part No	Description	Désignation Français
908177-001	TQP-RS low cover; external filterbox	TQP-RS bas-couvercle; boîte de filtre externe
908177-005	TQP-RS low cover; external filterbox; E85	TQP-RS bas-couvercle; boîte de filtre externe; E85
908177-002	TQP-RS low cover; external filterbox; low temp	TQP-RS bas-couvercle; boîte de filtre externe; grand froid
908177-006	TQP-RS low cover; external filterbox; E85; low temp	TQP-RS bas-couvercle; boîte de filtre externe; E85; grand froid
909043-003	TQP-RS low cover; internal filter; rear flexible connection	TQP-RS bas-couvercle; filtre interne; raccordement arrière flexible
909043-005	TQP-RS low cover; internal filter; rear flexible connection; E85	TQP-RS bas-couvercle; filtre interne; raccordement arrière flexible; E85
909043-004	TQP-RS low cover; internal filter; rear flexible connection; low temp	TQP-RS bas-couvercle; filtre interne; raccordement arrière flexible; grand froid
909043-006	TQP-RS low cover; internal filter; E85; rear flexible con; low temp	TQP-RS bas-couvercle; filtre interne; raccord. arrière flexible; E85; grand froid
908518-001	TQP-RS low cover; without filter	TQP-RS bas-couvercle; sans filtre
908518-005	TQP-RS low cover; without filter; E85	TQP-RS bas-couvercle; sans filtre; E85
908518-002	TQP-RS low cover; without filter; low temp	TQP-RS bas-couvercle; sans filtre; grand froid
908518-006	TQP-RS low cover; without filter; E85; low temp	TQP-RS bas-couvercle; sans filtre; E85; grand froid

This page is intentionally blank



- Manufacturing Plant
- Sales & Service Division
- Corporate Headquarters
- Joint Venture

For any further information and detailed contacts for each country, please visit our website at www.tokheim.com or e-mail us at info@tokheim-international.com

Contact

Corporate Headquarters

TOKHEIM GROUP SAS
 PARIS NORD 2
 BP 67040 TREMBLAY EN FRANCE
 95971 ROISSY CH DE GAULLE CEDEX
 FRANCE
 TEL: +33 (0)1 49 90 77 00
 FAX: +33 (0)1 49 90 77 77

Spare Parts

KOPPENS AUTOMATIC
 (BLADEL)
 INDUSTRIEWEG 5
 5531 AD BLADEL
 THE NETHERLANDS
 TEL: +31 497 389 555
 FAX: +31 497 381 9507

Manufacturing

WEST PITKERRO INDUSTRIAL ESTATE
 DUNDEE DD5 3RT
 SCOTLAND
 UNITED KINGDOM
 TEL: +44 (0)1382 598000
 FAX: +44 (0)1382 598017

Manufacturing

ROUTE DE SOLIERS
 BP 268 - 14540 GRENTHEVILLE
 14013 CAEN CEDEX
 FRANCE
 TEL: +33 (0)2 31 15 15 15
 FAX: +33 (0)2 31 23 15 06

For Technical manual enquiries, contact: author@dundee.tokheim.com